



IMC MF15 FREE-STANDING VEGETABLE PEELER - WITH ONION PLATE - 3 PHASE - W 481 MM - 0.37 KW

MODEL: F59/740



MF
MULTI-FUNCTIONAL
PEELER

PRODUCT OPTIONS AND ACCESSORIES

- S59/166 Onion Peeling Plate for MF10/MF15 Vegetable Peeler

The versatile, energy-efficient MF15 Onion peeler (3PH) is the ideal onion peeler for medium to large kitchens with three-phase power supply.

With a thick peeling plate for long operating life, the MF15 Onion (3PH) is able to peel up to 202kg of onions per hour in 15kg batches making it a cost-effective and labour-saving solution. For best results, we recommend onions are topped and tailed before peeling, and hand finished afterwards.

Easy to operate, the unit comes with an integral stand and removable filter basket. It has an interlocking lid and door for user safety. The MF15

PRODUCT FEATURES

- Able to peel up to 202kg of onions per hour - in 15kg batches.
- Smooth stainless steel waste outlet prevents blockages and build-up of peelings.
- Interlocking lid and door ensure safe operation.
- Perspex viewing pane allows you to monitor the peeling progress.
- Adjustable timer ensures accurate, repeatable peeling times.
- Modular construction facilitates easy maintenance.
- Thicker peeling plate delivers longer operating life.
- Suitable for medium to large kitchens with three-phase power supply.

AIA FILE NUMBER:

ITEM NUMBER:



IMC MF15 FREE-STANDING VEGETABLE PEELER - WITH ONION PLATE - 3 PHASE - W 481 MM - 0.37 KW

MODEL: F59/740

WEIGHTS & DIMENSIONS

Width	481 mil
Depth	629 mil
Height	1171 mil
Weight	51.5 kg

SHIPPING DETAILS

Ship Width	68 cm
Ship Depth	51 cm
Ship Height	125 cm
Ship Weight	62.5 kg
Ship Method	Small Parcel (FedEx, UPS, DHL)
Shipping Package Type	Pieces
Shipping Origin Zip Code	LN6 3QZ, UNITED KINGDOM
Quick Ship Product	No

WATER, PLUMBING, AND DRAINAGE SPECS

Drain Line Required	Yes
Drain Outlet Size	38 mm

PRODUCT CERTIFICATIONS



ENERGY SPECS

Primary Energy Type	Electric
Electrical Total Amperage	3.6 A
Electrical Volts	400V
Electrical Total Wattage	370 W
Electrical Kilowatts	0.37 kW
Electrical Phase	3-Phase

Electrical Plug Type	Hardwired
Number of Electrical Plugs	Not Applicable
Electrical Connection Type	Direct Hardwired
Number of Electrical Conductor Wires	1
Dedicated Circuit Required	Yes
Electrical Remarks	Three

ADDITIONAL SPECIFICATIONS

Airbreak	Yes
Construction Materials	Stainless Steel
Control Type	On/Off, Rotary Control Knob
Hopper Load	15 kg
Motor Power	0.5 hp
Operator Safety Method	Interlock
Processing Capacity Per Hour	202 kg
Timer Type	Mechanical/Traditional Timer

BIDDING SPECIFICATIONS (SHORT FORM SPECS)

Bidding Specifications Not Available.

IMC reserves the right to modify specifications or discontinue models without incurring obligation. Dimensions nominal.

Document Auto-Generated
March 24, 2025





IMC MF15 FREE-STANDING VEGETABLE PEELER - WITH ONION
PLATE - 3 PHASE - W 481 MM - 0.37 KW

MODEL: F59/740

TECHNICAL DRAWING

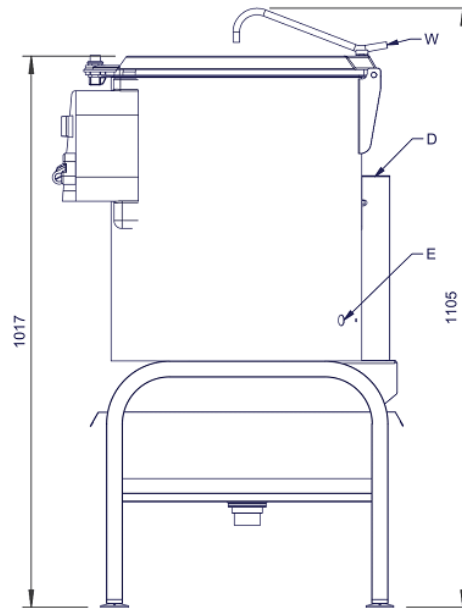
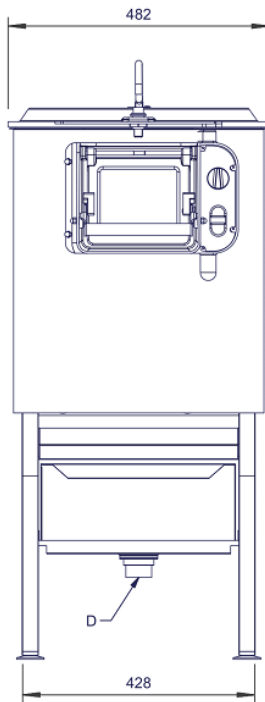
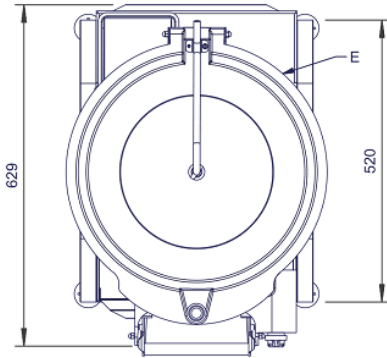

IMC reserves the right to modify specifications or discontinue models without incurring obligation. Dimensions nominal.

Document Auto-Generated
March 24, 2025